

MFJ-941D VERSA TUNER II INSTRUCTIONS

Thank you for purchasing the MFJ-941D VERSA TUNER II. The MFJ-941D is designed to match vees, verticals, mobile whips, beams, random wires, and others fed by coax lines, balanced lines, or a single wire. A 1:4 balun is built in for connection to balanced lines. This unit will handle up to 300 watts of RF output power from the transmitter from 160 through 10 meters. The MFJ-941D will monitor either SWR or RF transmitter power in two ranges, 30W or 300W. The antenna selector switch allows switching to one of the two coax fed antennas (direct or through tuner) and either a balanced line antenna or random wire antenna. A bypass position allows switching to a dummy load or a direct coax antenna. The tuner is bypassed but not the meter circuit when the ANTENNA SELECTOR switch is switched to BYPASS, DIRECT COAX 1, or DIRECT COAX 2 positions.

CAUTION: Do not use the MFJ-941D for over 300 watts of RF output power, even in the bypass or direct positions. Do not operate the antenna selector while transmitting.

INSTALLATION

1. Install the MFJ-941D between the transmitter and the antennas. A coax line is connected between the transmitter and the SO-239 coax connector marked TRANSMITTER on the tuner.
2. One or two coax fed antennas may be connected to the SO-239 coax connectors marked COAX 1 and COAX 2. NOTE: Coax 1 and coax 2 antennas can be connected directly to the transmitter by turning the antenna selector to COAX 1 DIRECT or COAX 2 DIRECT.
3. A random wire antenna may be connected to the five-way binding post marked WIRE. The random wire antenna should be long, high, and as clear of surrounding objects as possible. Do not ground the random wire antenna but make sure that the tuner is well grounded to the transmitter. A five-way binding post, marked GND, is provided for the ground connection.
4. A balanced line fed antenna may be connected to the two five-way binding posts marked BALANCED LINE, along with a jumper wire from the WIRE binding post to the adjacent BALANCED LINE binding post, as indicated by a dotted line on the MFJ-941D. This couples the MFJ-941D to the balanced line through a 1:4 balun. NOTE: Either a balanced line or random wire antenna can be connected at one time. If a random wire antenna is used, make sure that there is not a jumper wire between WIRE and BALANCED LINE.
5. An antenna or dummy load may be connected to the SO-239 coax connector marked BYPASS COAX. The antenna switch on the BYPASS position will bypass the tuner and allow the MFJ-941D to be used as an SWR meter or a wattmeter.

THE SWR/WATTMETER

The SWR/WATTMETER of the MFJ-941D can be used with the tuner or by itself. The SWR/WATTMETER is between the transmitter and the tuner when the antenna switch is in the COAX 1, COAX 2, or WIRE/BAL positions. The SWR meter is sensitive down to approximately 5 watts RF output. The SWR reading will not be accurate for a transmitter power of less than 5 watts.

FORWARD AND REFLECTED POWER

1. Set the POWER/SWR switch to POWER.
2. Set the 300/30 watt switch for the desired range.
3. Set the FWD/REF switch in for forward, out for reflected power.
4. Transmit a steady carrier and read the power.

SWR MEASUREMENT

1. Set the POWER/SWR switch out.
 2. Set the FWD/REF switch in.
- NOTE: It does not matter which position the 300/30 watt switch is in for measuring SWR.
3. Transmit and adjust the SWR SENSITIVITY control for full scale reading.
 4. Set the FWD/REF switch out and read the SWR.

OPERATION OF THE TUNING SECTION

The INDUCTANCE switch on the MFJ-941D presents a minimum of inductance at position "A" and a maximum of inductance at position "L". Less inductance is needed at high frequencies for the same impedance. The TRANSMITTER and ANTENNA controls both present a maximum of capacitance at position 6.

For optimum operation of the MFJ-941D, the transmitter must be tuned for a 50 ohm output impedance for the frequency band in operation. The transmitter can be tuned with the MFJ-941D connected by connecting the 50 ohm load to the BYPASS COAX connector and turning the antenna switch to the BYPASS position. The MFJ-941D is then used only as an SWR meter or a wattmeter. NOTE: Always tune the transmitter at a low output power.

After properly tuning the transmitter, turn the antenna switch to the desired antenna and tune the tuner for minimum SWR as described below. Do not readjust the transmitter setting after loading it to the 50 ohm load.

1. Set the TRANSMITTER and ANTENNA controls to 3.5. (The capacitors are half opened).
2. Rotate the INDUCTANCE control until maximum noise is obtained in the receiving mode.
3. Set the POWER/SWR switch to SWR and the FWD/REF switch to FWD. It does not matter which position the 300/30 watt switch is in

for measuring SWR. Set the transmitter to the tune position and transmit.

4. Turn the SWR SENSITIVITY control clockwise until a full-scale deflection is obtained. If a full-scale deflection cannot be obtained, increase the output power from the transmitter.
5. Set the FWD/REF switch to the REF for the SWR reading.
6. If the SWR is not 1:1, then tune the MFJ-941D for a minimum SWR.
7. While transmitting, and with the INDUCTANCE control set the same as for Step 2, alternately adjust the TRANSMITTER and ANTENNA controls for a minimum SWR. Since the TRANSMITTER and ANTENNA controls interact, the two controls can best be adjusted by turning the TRANSMITTER control at a small increment at a time and then rotating the ANTENNA control for the minimum SWR. Repeat this until a minimum SWR is obtained.
8. If a SWR reading of 1:1 is not achieved, increase or decrease the INDUCTANCE control one position and repeat STEP 7.
NOTE: If a SWR cannot be achieved at this point, repeat Step 7 for each INDUCATNCE control position. Again, do this in the tune mode or at a low transmitting power.
9. After a minimum SWR is achieved, readjust the SWR sensitivity (to get a more accurate reading of the SWR) by pushing the FWD/REF switch in to FWD and adjust the SWR SENSITIVITY control for a full scale meter deflection. Switch the FWD/REF switch to the REF position for the SWR reading. The transmitted power may now be switched to 300 watts. The SWR sensitivity must be reset again after full power is applied. The ANTENNA and TRANSMITTER controls may need fine adjustment if the SWR is not 1:1 at high power.
NOTE: On the 160 meter band, excessive heating or arcing may occur. Reduce the transmitter output power until it stops.
10. To read the transmitter power, push the POWER/SWR switch in to POWER and the 300/30 watt switch to whichever power scale you want. To read reflected power, put the FWD/REF switch in the REF position.
11. A SWR of 1:1 can occur from more than one set of control settings on the MFJ-941D. When a SWR of 1:1 is obtained, be sure to check transmitter power and make sure that the transmitter power is relatively high. If the transmitter power has decreased substantially, try another INDUCTANCE control setting and repeat Step 7.
12. When using the MFJ-941D for receiving only, tune the MFJ-941D as described in Step 1 and Step 2.

ADDITIONAL NOTES AND CAUTIONS

1. Do not use the MFJ-941D for over 300 watts of RF output power, even in the BYPASS or the DIRECT COAX positions.
2. Do not operate the antenna switch while transmitting.
3. For recalibrating the power scale settings, use the trim pots just behind the meter. Looking from the front, the left trimpot adjusts the 300 watt scale and the right adjusts the 30 watt scale.

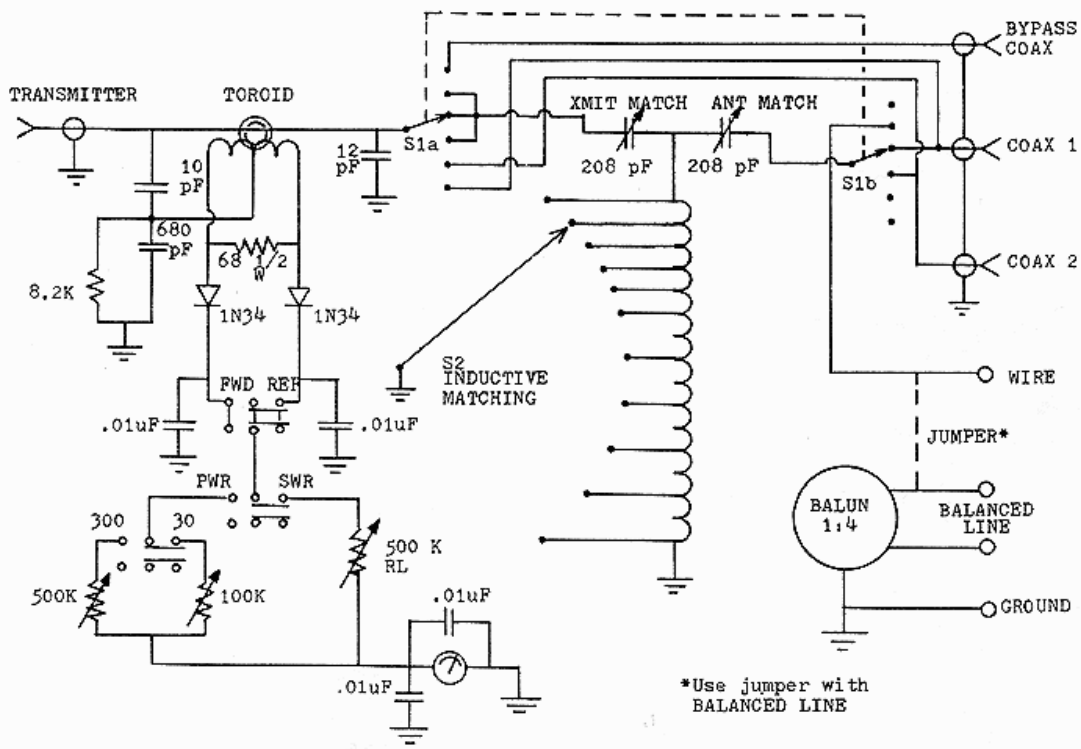

MFJ-941D SCHEMATIC DIAGRAM